

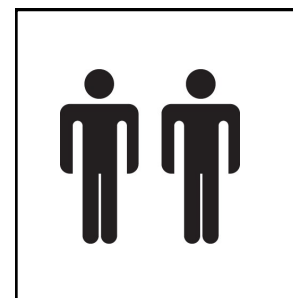

Caisson 5 tiroirs.

Blok 5 schuiven.

5-drawers box.

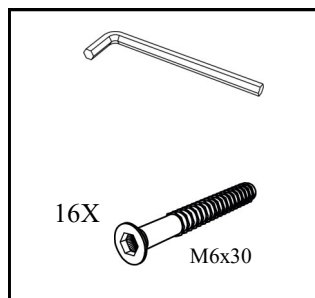
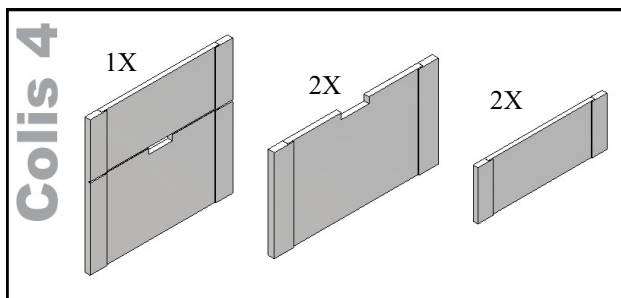
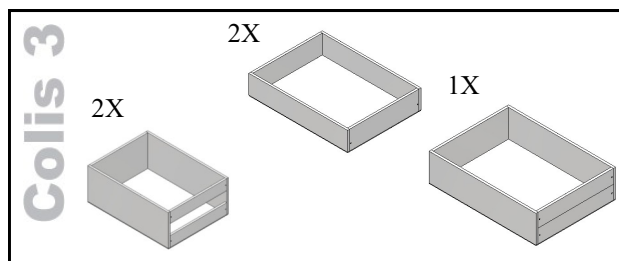
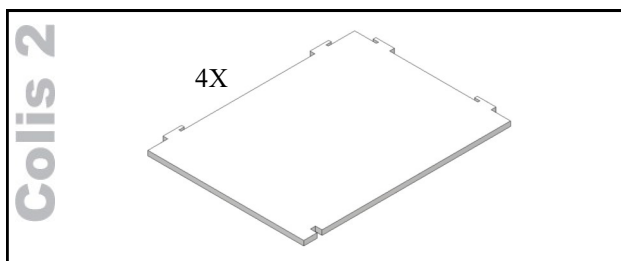
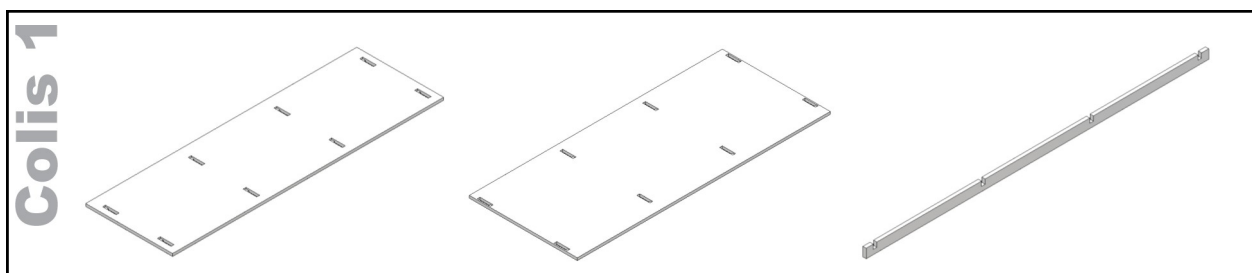
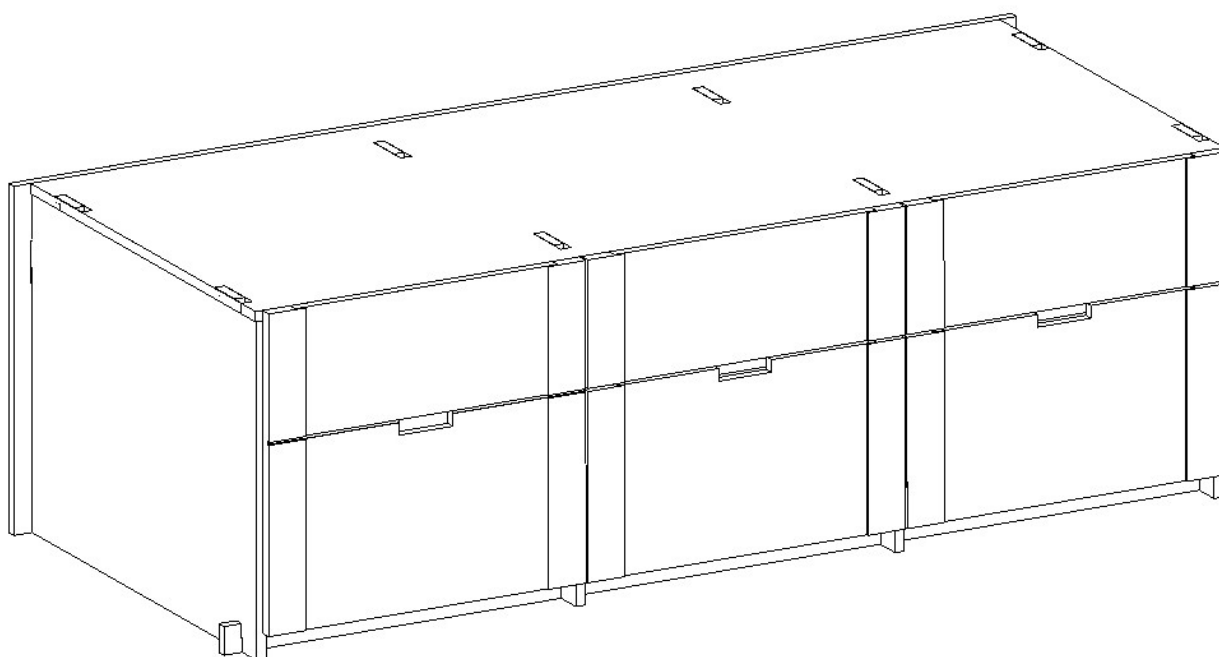



MATHYBYBOLS

1

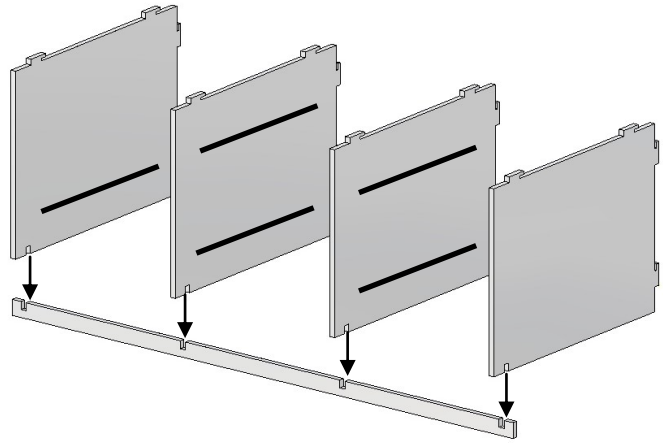
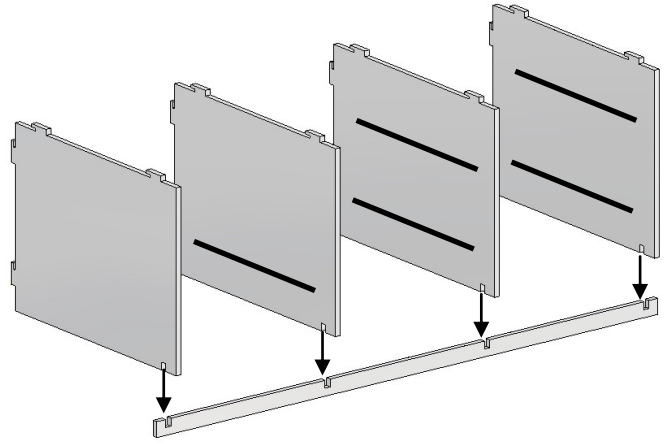
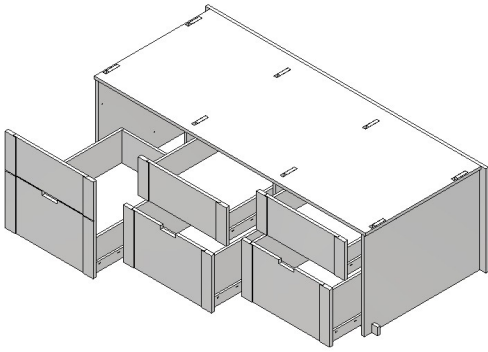
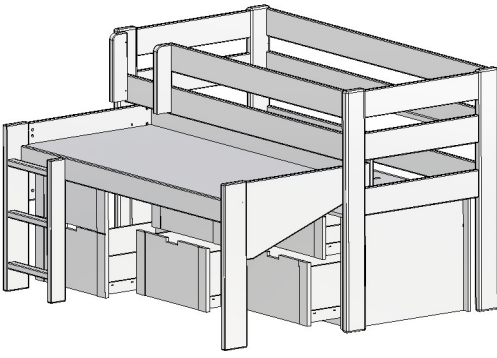

2

1

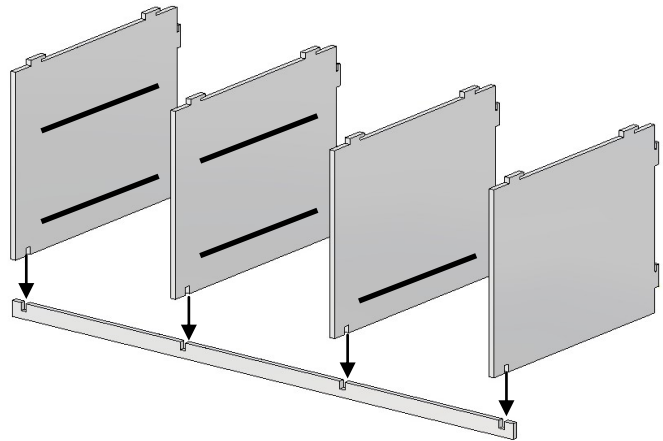
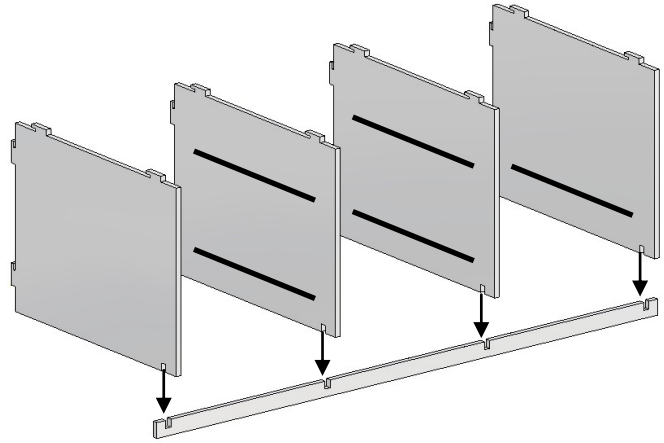
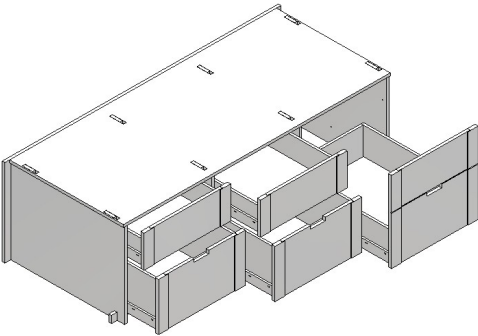
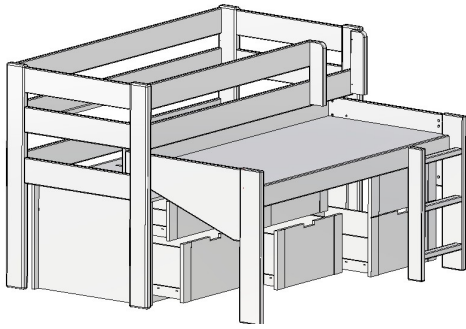



2

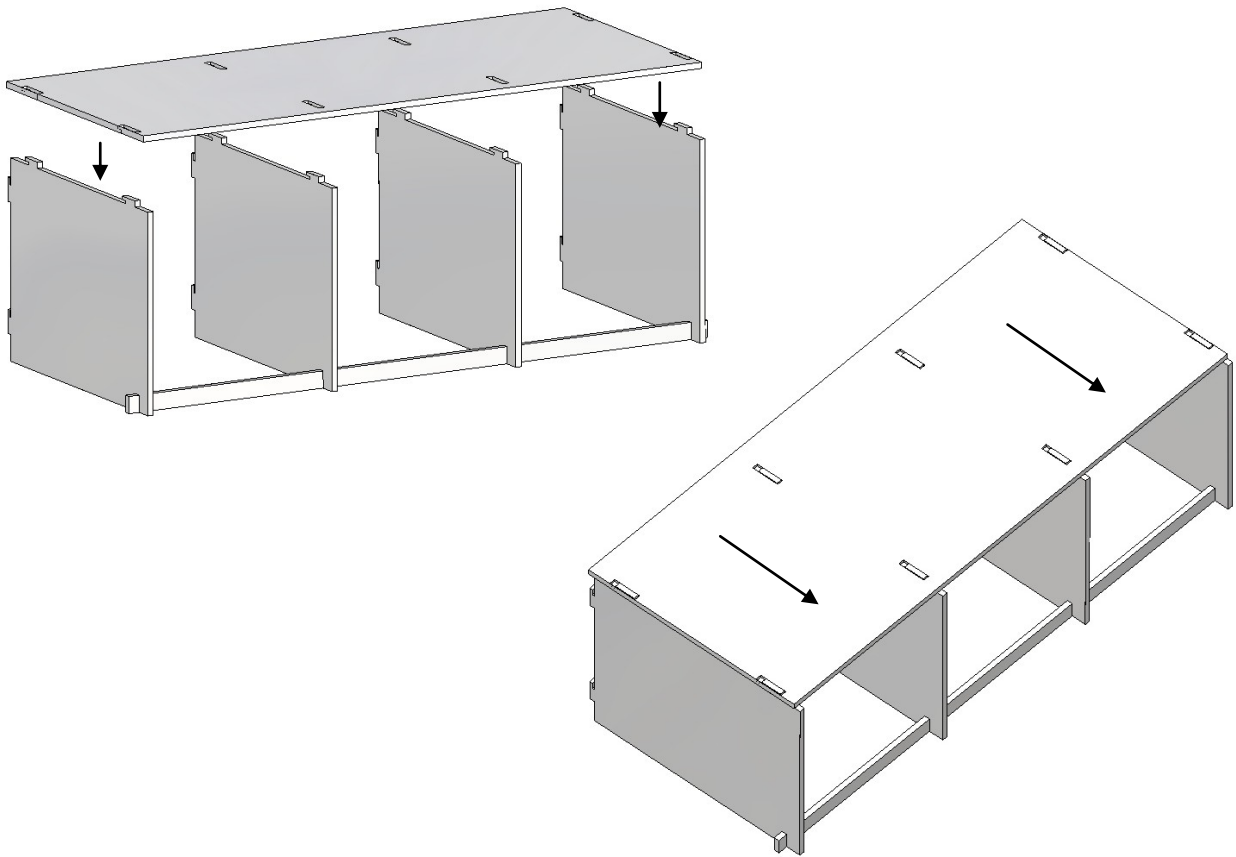

3

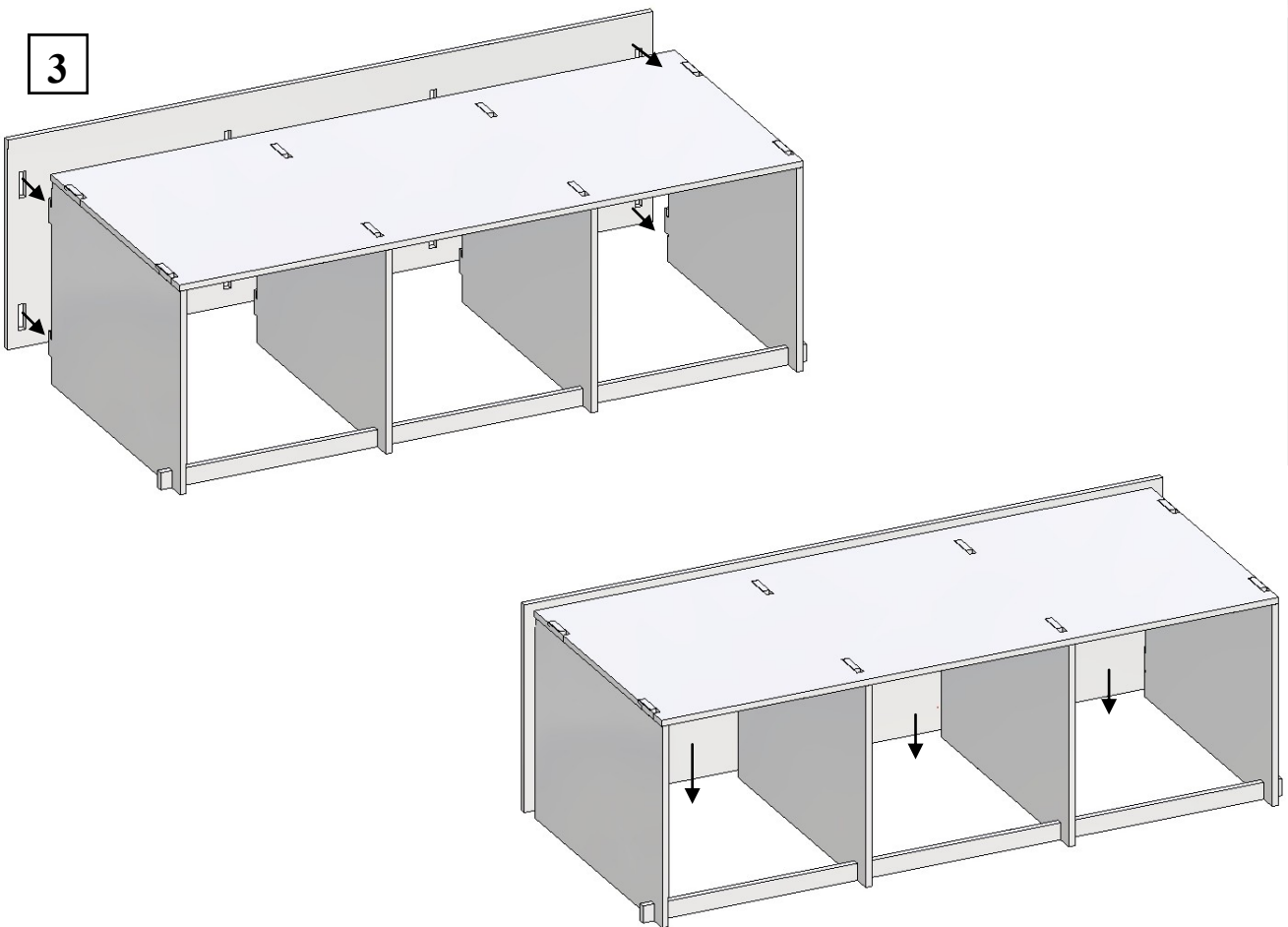



4

MATHYBYBOLS

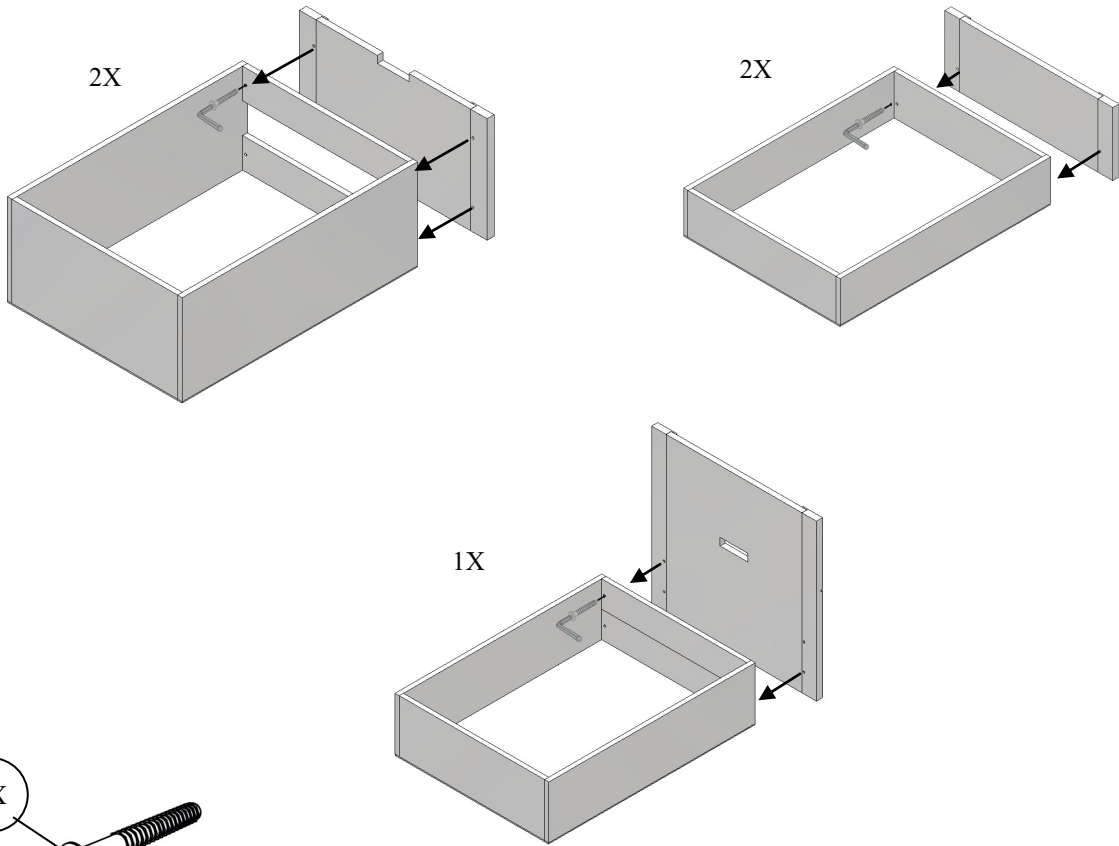

4

5

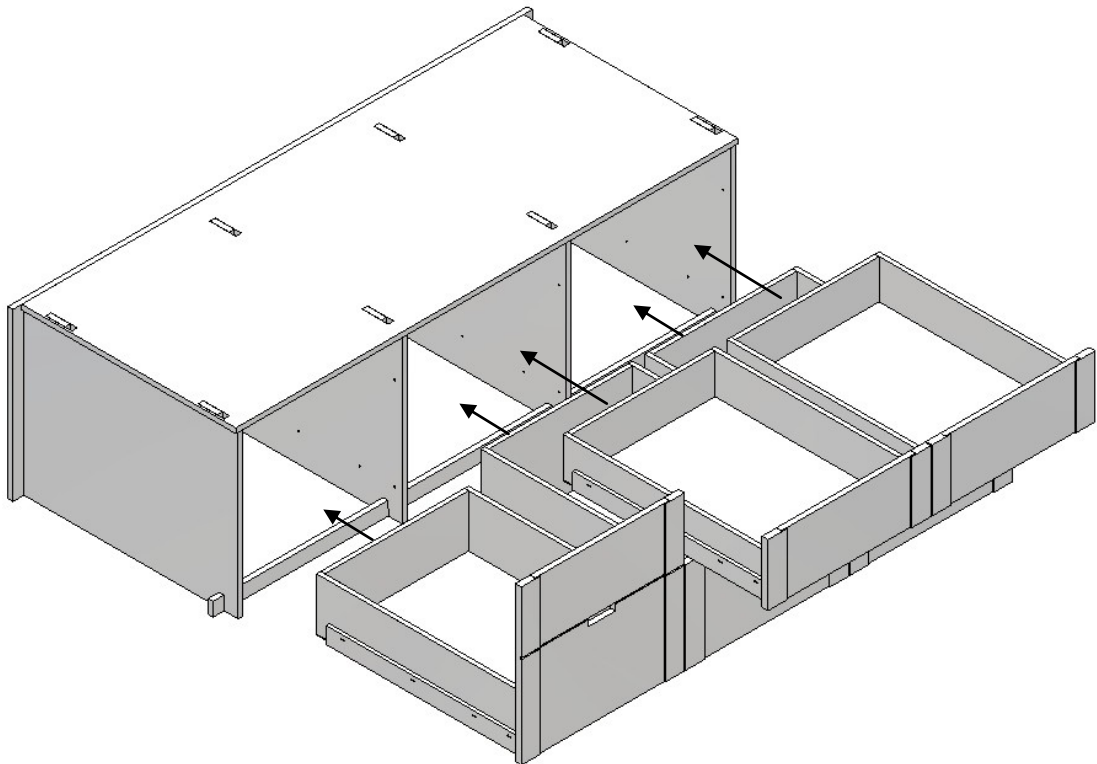



# Rollenführungen

Roller slides/Coulisses à galets/Guide a rotelle/Guías de rodillos

Deutsch	English	Français	Italiano	Español
<b>Montage-Anleitung</b> Vollauszug selbst-schließend - 50 kg	<b>Mounting instructions</b> full extension runner 50 kg (DIN) 150 lbs (ANSI/BIFMA)	<b>Instructions de montage</b> pour coulisse à sortie totale 50 kg	<b>Istruzioni di montaggio</b> per la guida ad estrazione totale chiusura automatica - 50 kg	<b>Instrucciones de montaje</b> riel de extension cierre automatico - 50 kg
<b>Drehriegel</b>	<b>Twist-lock</b>	<b>Pièce tournante</b>	<b>Gancio rotante</b>	<b>Twist-lock</b>
Die innovative Lösung: Patentierter Vollauszug mit Drehriegel!	Patented Full Extension Runner with "Twist Lock"! The innovative solution.	La solution innovatrice est la coulisse à sortie totale avec sa pièce tournante!	La soluzione: Guide ad estrazione totale con gancio rotante.	La solución innovativa: El riel de extension patentado con seguro "Twist-Lock".

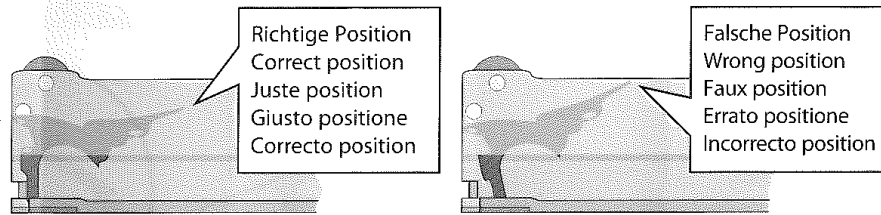

<b>Drehriegel-Funktion:</b> - für funktionierenden Selbsteinzug - für sichere Tragkraft von 50 kg - für einfaches Ein- und Aushängen der Schublade	<b>"Twist-Lock" offers:</b> - guaranteed self-close function - load capacity of 50 kg or 150 lbs - easy drawer insertion and removal	<b>La pièce tournante offre:</b> - fermeture automatique qui fonctionne - capacité de charge aussi élevée (50 kg) - montage et démontage du tiroir plus faciles	<b>Con gancio rotante:</b> - con chiusura automatica - per la portata di 50 kg - per un inserimento e uno scardinamento del cassetto più semplice	<b>Con el seguro "Twist-Lock":</b> - hay cierre automático - su capacidad de carga es de 50 kg - facilidad de inserción y de remover el cajón
<b>Einhängen der Mittelschiene</b>	<b>Insertion of intermediate profile</b>	<b>Position d'accrochage du rail du milieu</b>	<b>Aggancio del profilo intermedio</b>	<b>Inserción del riel medio</b>

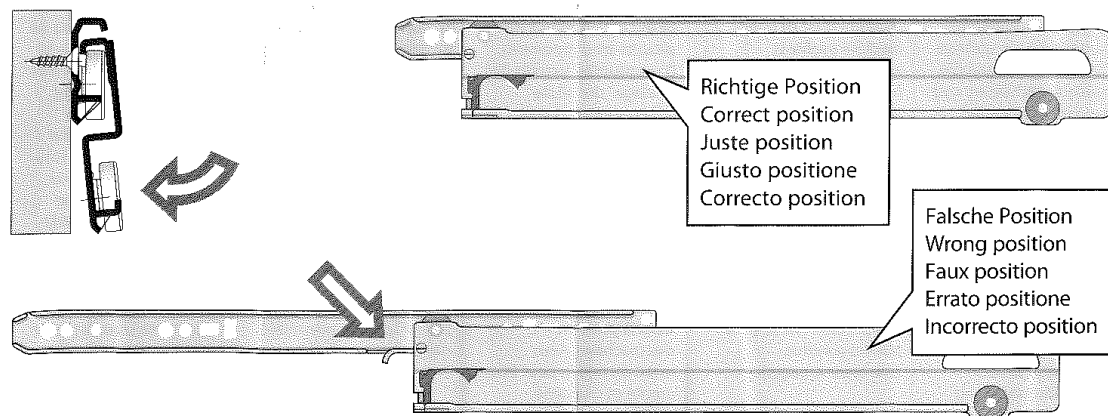



# Rollenführungen

Roller slides/Coulisses à galets/Guide a rotelle/Guías de rodillos

Deutsch	English	Français	Italiano	Español
Einhängen Sichern Aushängen der Schublade	Insertion Securing Removal of drawer	Accrocher bloquer démonter le tiroir	Inserimento Sicurare Sganciamento del assetto	Inserción como colocar el seguro como remover el cajón
Einfahren der Lade in die Mittelschiene	Insertion of drawer into intermediate profile	Positionner le tiroir sur le rail du milieu	Inserimento del cassetto nel profilo intermedio	Inserción del riel medio en el cajón

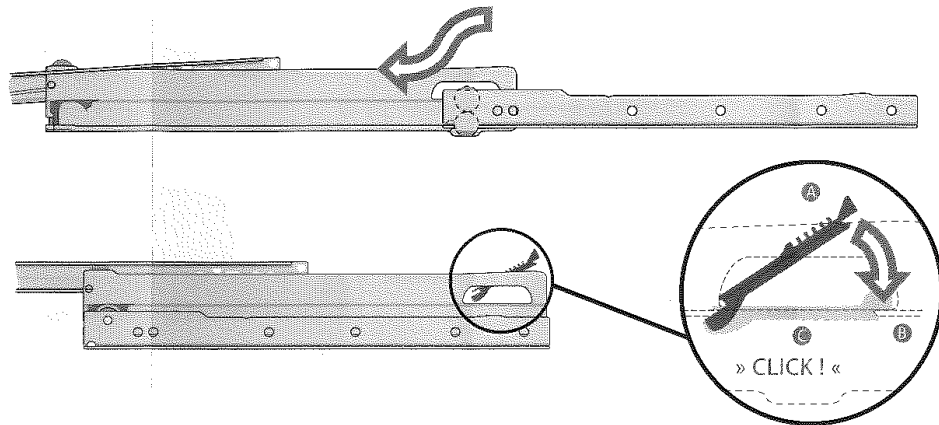

In der Korpuschiene beige packt ist ein Paar schwarze Abdeckkappen. Diese trennen und bei ausgezogener Schublade in die vorgesehenen Öffnungen der Mittelschiene in Pfeilrichtung einschieben **A** und eindrücken **B**. Die Abdeckkappe dient zugleich als Aushängesicherung die ein unbeabsichtigtes Aushängen der Schublade verhindert und einen entscheidenden Sicherheitsaspekt darstellt. Eventuelle "Lauffehler" der Mittelschiene werden durch vollständiges Ausziehen der Lade automatisch korrigiert. Aushängen der Schublade: Bis zum Anschlag ausziehen, Abdeckkappe in der Mitte anheben **C** und aushängen. Drehringel in die Einhängesicherung bringen. Dadurch kann die Mittelschiene eingeschoben und gegebenenfalls ausgehängt werden.

One pair of black cover caps is supplied with each set of full extension slide. Separate cover caps and insert into openings of left and right intermediate profile - pay attention to direction of arrow! **A** + **B**. Cover caps serve also as safety locks respectively pull out stops. "Malfunction" of intermediate profile is automatically rectified by fully extending the drawer and pushing back in again. Removal of drawer: When reaching stop position of drawer, remove cover cap by lifting cap in the center **C** and take out drawer. For insertion and removal of intermediate profile, "Twist Lock" has to be in correct position (see reverse page!)

Les rails meubles sont livrés avec une paire de caches noirs. Posez ces caches de chaque côté dans la position prévue sur le rail du milieu sorti - il faut faire attention à la direction de la flèche! **A** + **B**. Le cache évite une sortie involontaire du tiroir, ce qui est un aspect de sécurité très important. D'éventuelles "erreurs de guidage" du rail du milieu sont corrigées automatiquement en sortant le tiroir complètement. Décrochage du tiroir: Sortir le tiroir jusqu'à la butée, soulever le cache au centre **C**, enlever le cache et retirer le tiroir. Mettre la pièce tournante dans la position d'accrochage. Ainsi le rail du milieu peut être monté et démonté.

Ogni coppia di guide contiene un paio di placche coprimecanismo nere, le quali vengono separate, e montate: **A**: inserimento nel senso della freccia **B**: incastro Il fermo di sicurezza impedisce uno sganciamento involontario del cassetto. Se fossero "errori di scorrevolezza" dei profili intermedi, si correggono tra la estrazione totale del cassetto. Sganciamento del cassetto: Estrarre il cassetto fino in battuta, smontare le placche di sicurezza dai profili intermedi **C** e sganciare il cassetto. Portare il gancio rotante nella posizione di aggancio, in modo che il profilo intermedio possa essere spinto e eventualmente smontato.

En el riel del mueble encontrará un par de tapas de cubierta de color negro. Sepárelos e insérteles en los orificios del riel de la mitad en dirección de la flecha. **A** + **B** Estas tapas de cubierta previenen igualmente que el cajón se safe o se caiga accidentalmente, lo cual representa una medida de seguridad óptima para el consumidor final. Además estas tapas de cubierta garantizan un seguro óptimo cuando el cajón está extendido en su totalidad. En caso de que el riel medio no funcione correctamente, se corrige abriendo el cajón en su extensión total y cerrándolo nuevamente. Para remover el cajón: Abra el cajón hasta la posición de seguro, remueva la tapa de cubierta negra **C** y saque el cajón. Para remover e insertar el riel de la mitad, empuje el "twist-lock" a la posición de inserción.