

# 6900BATV

PARISOT INDUSTRIE 70800 SAINT LOUP SUR SEMOUSE -FRANCE-

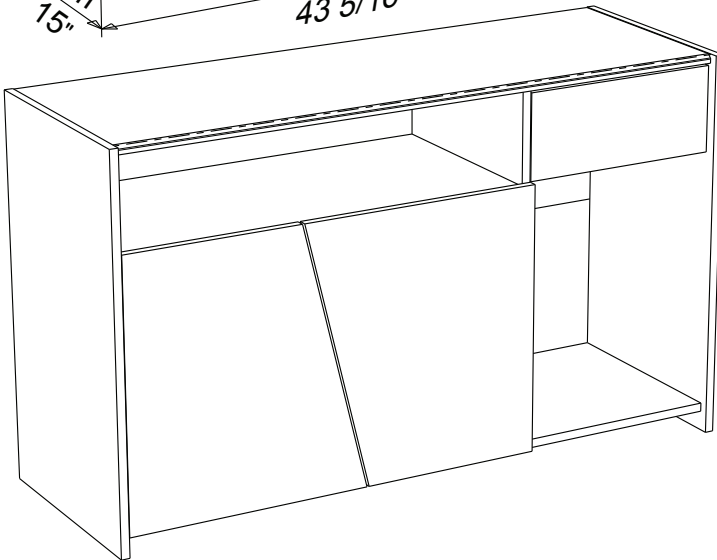
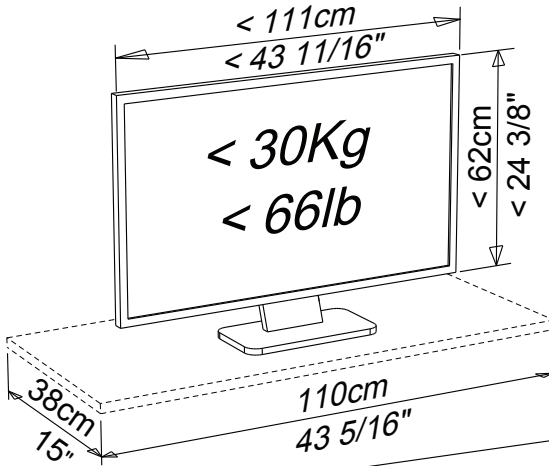

Gamme : GAME

PARISOT INDUSTRIE

## FR Remerciements :

Nous vous remercions d'avoir choisi un meuble créé et fabriqué par le Groupe Parisot et espérons qu'il vous donnera entière satisfaction.

## EN Thanks:

Thank you for choosing furniture designed and manufactured by the Parisot Group.

We hope you are totally satisfied with your purchase.

## DE Danksagung:

Wir danken Ihnen für den Kauf eines Frankreich von der Parisot-Gruppe entwickelten und hergestellten Möbelstücks und hoffen, dass Sie es zu Ihrer vollkommenen Zufriedenheit finden werden.

## HU Köszönet:

Köszönjük, hogy a Parisot Groupe által létrehozott és gyártott bútort választott, reméljük, hogy elégedett lesz a termékkel.

## PT Agradecimentos:

Obrigado por ter escolhido um móvel concebido e fabricado pelo Grupo Parisot, esperando que seja do seu inteiro agrado.

## IT Ringraziamenti:

Grazie per avere scelto un mobile progettato e fabbricato dal Gruppo Parisot. Speriamo soddisfatti appieno le vostre esigenze.

## NL Bedankje:

Wij bedanken u voor de aankoop van een door de Groep Parisot ontworpen en vervaardigd meubel en hopen dat u er veel plezier aan zult beleven.

## CZ Poděkování:

Děkujeme, že jste si vybrali nábytek navržený a vyrobený společností Parisot Group. Doufáme, že budete svým nákupem naprosto spokojeni.

## ES Agradecimientos:

Les damos las gracias por haber elegido un mueble diseñado y fabricado por el Groupe Parisot y esperamos que sea de su total agrado.

## PL Podziękowania:

Dziękujemy za wybór mebli stworzonych i wyprodukowanych przez Grupę Parisot. Mamy nadzieję, że będziecie Państwo w pełni zadowoleni z zakupu.

## SK Pod'akovanie:

Ďakujeme, že ste si vybrali nábytok navrhnutý a vyrobený spoločnosťou Parisot Group. Dúfame, že budete svojim nákupom absolútne spokojní.

## AR شكر:

نشكركم لاختياركم هذه القطعة من الأثاث من تصميم وتصنيع مجموعة باريسو Parisot وتتمنى أن تنال رضاءكم.

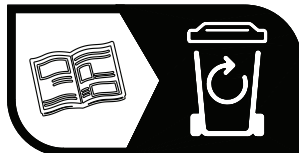
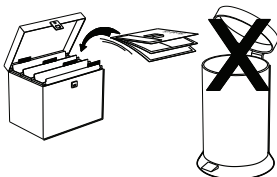

FR

Donnez ou recyclez vos meubles.



ou



ou



Association

Magasin

Déchèterie

<https://quefairedemesdechets.fr>

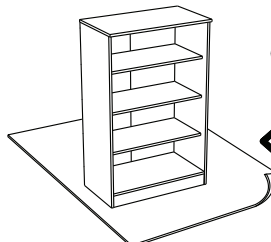
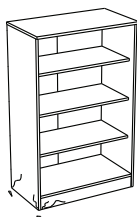
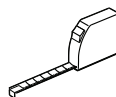
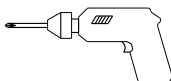
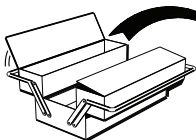

67.5cm  
26 1/2"  
113.5cm  
44 3/4"  
40cm  
15 3/4"

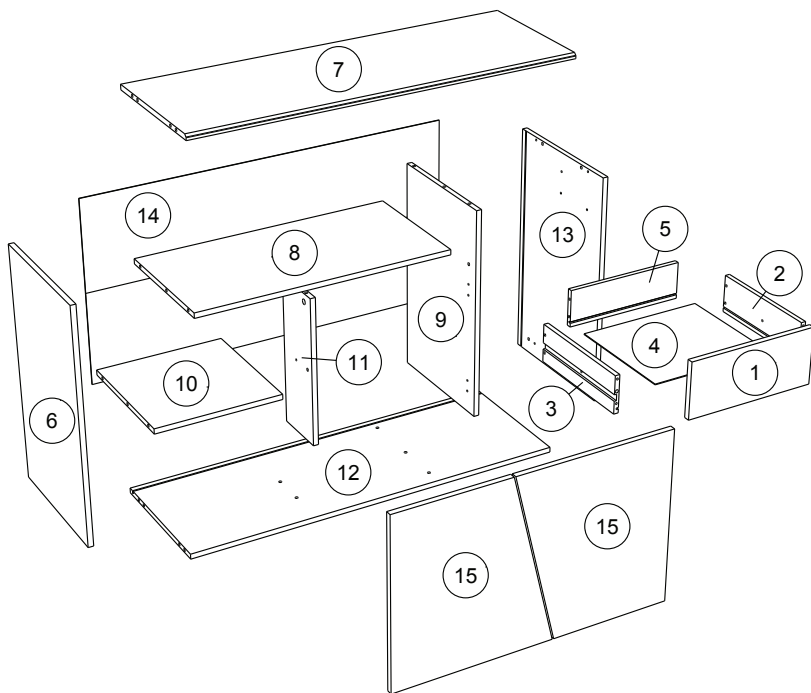

		mm			inch		
①	x 1	350	151	15	13 3/4	5 15/16	9/16
⑩	x 1	360	359	15	14 3/16	14 1/8	9/16
⑪	x 1	433	155	15	17 1/16	6 1/8	9/16
⑮	x 2	468	428	15	18 7/16	16 7/8	9/16
⑨	x 1	608	361	15	23 15/16	14 3/16	9/16
⑥	x 1	673	398	15	26 1/2	15 11/16	9/16
⑬	x 1	673	398	15	26 1/2	15 11/16	9/16
⑧	x 1	732	360	15	28 13/16	14 3/16	9/16
⑦	x 1	1101	382	15	43 3/8	15 1/16	9/16
⑫	x 1	1101	382	15	43 3/8	15 1/16	9/16
②	x 1	300	100	13	11 13/16	3 15/16	1/2
③	x 1	300	100	13	11 13/16	3 15/16	1/2
⑤	x 1	321	100	13	12 5/8	3 15/16	1/2
④	x 1	333	299	2	13 1/8	11 3/4	1/16
⑭	x 1	1117	564	2	44	22 3/16	1/16

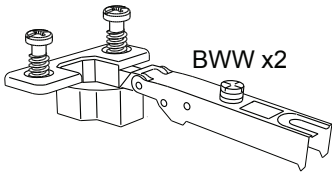

BWW x2

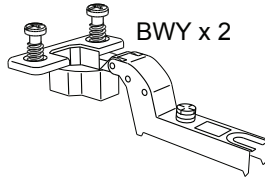

BWY x2



CG x2

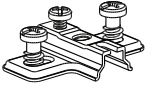

BWU x4

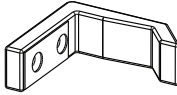

CSM x1



EP x4



BAG x2

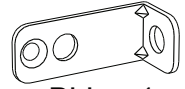

BLL x1

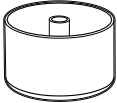

DR x2

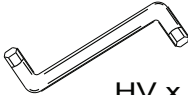

HV x1



Ai x14



BZG x2

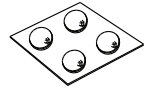

AQO x1

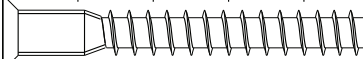
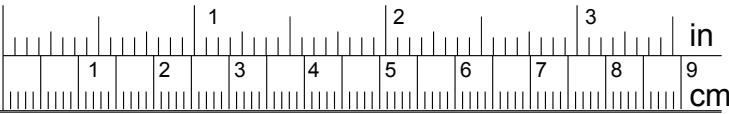

HW x3

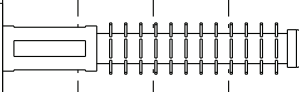

CQA x4

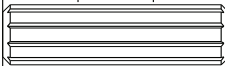
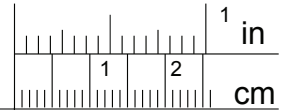

ADM x20

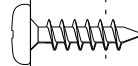

VE x5



ADU x4

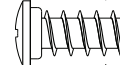

VB x2

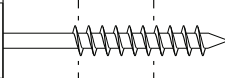

WH x2

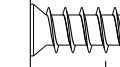

BWF x4

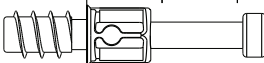

BSD x16



ANK x1

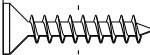

WJ x2

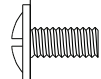

VR x2

1

BSD x 2

ADU x4

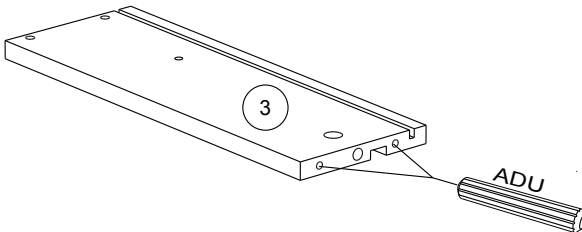
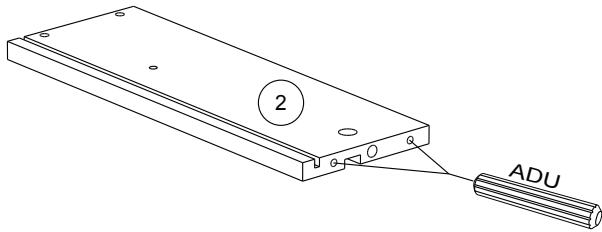
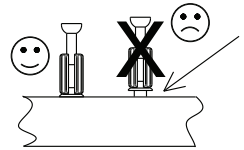
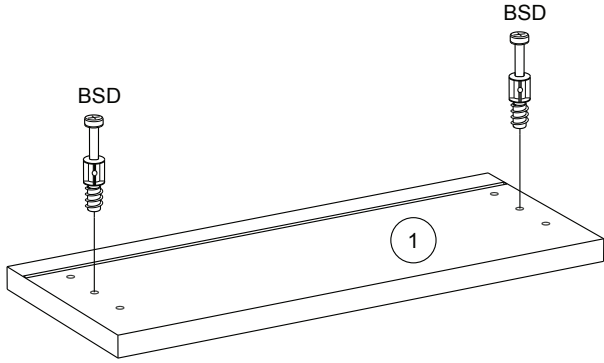
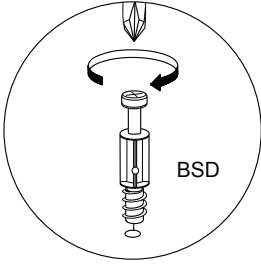

2



BZG x 2



CQA x 4

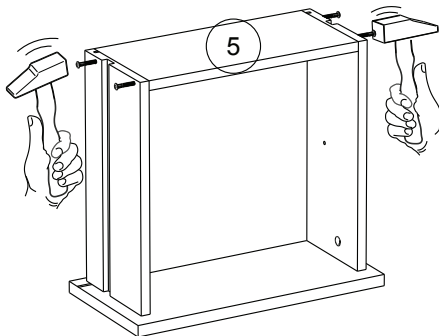
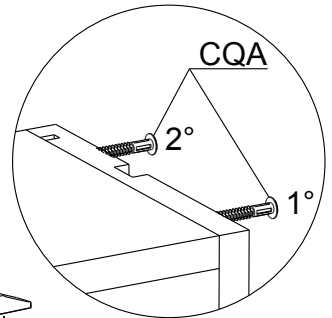
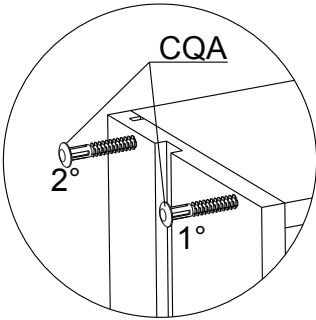
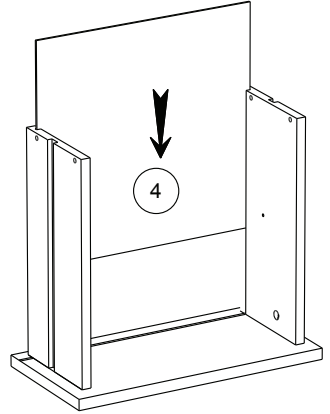
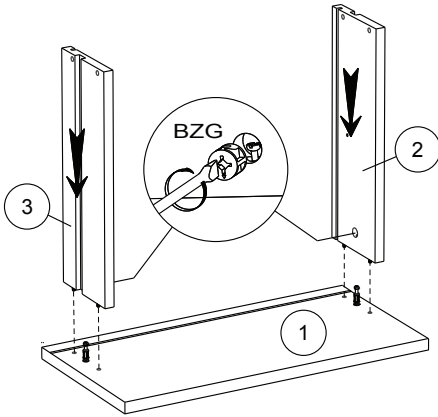

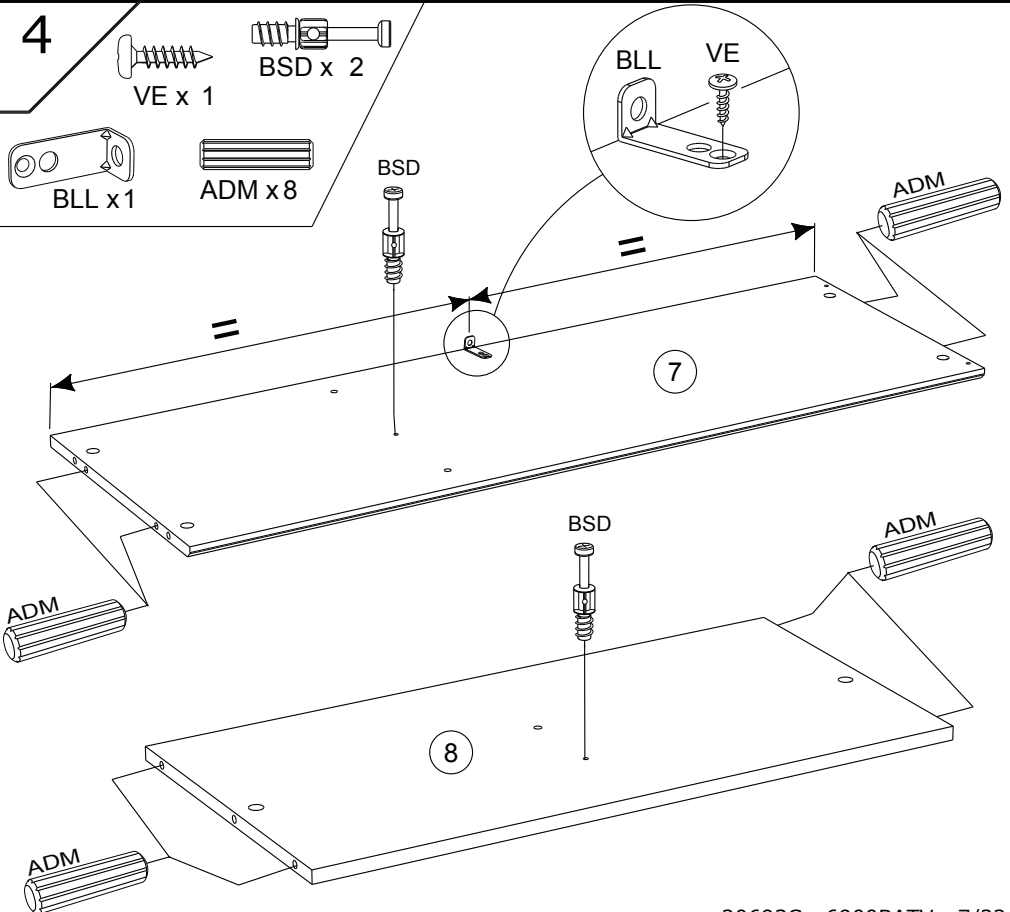
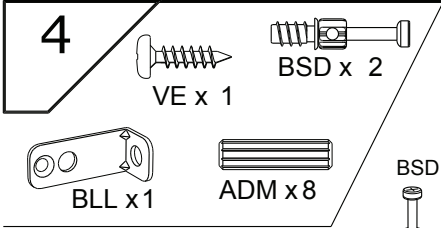
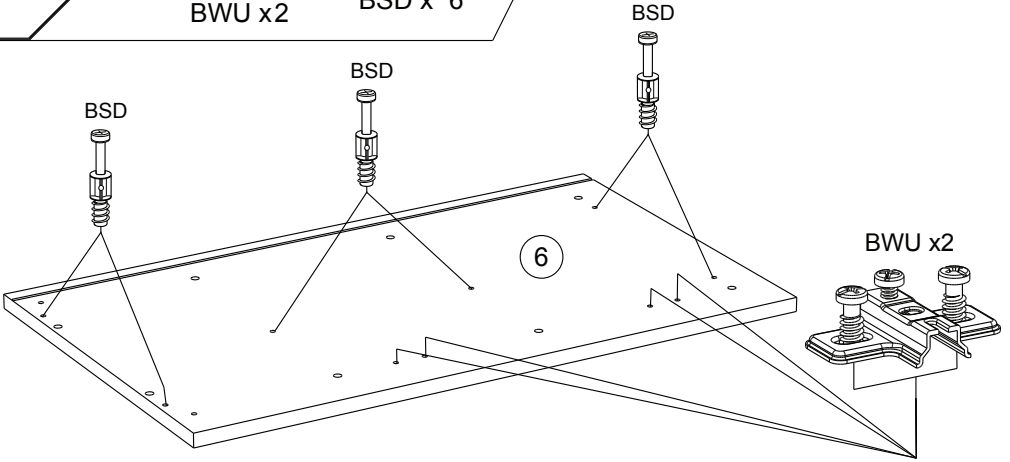
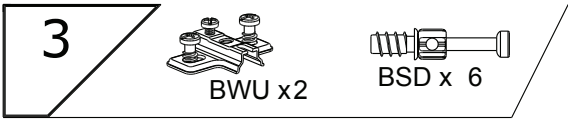

5

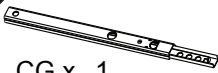

CG x 1



ADM x 3



BWF x 2



BSD x 1



BWU x 2

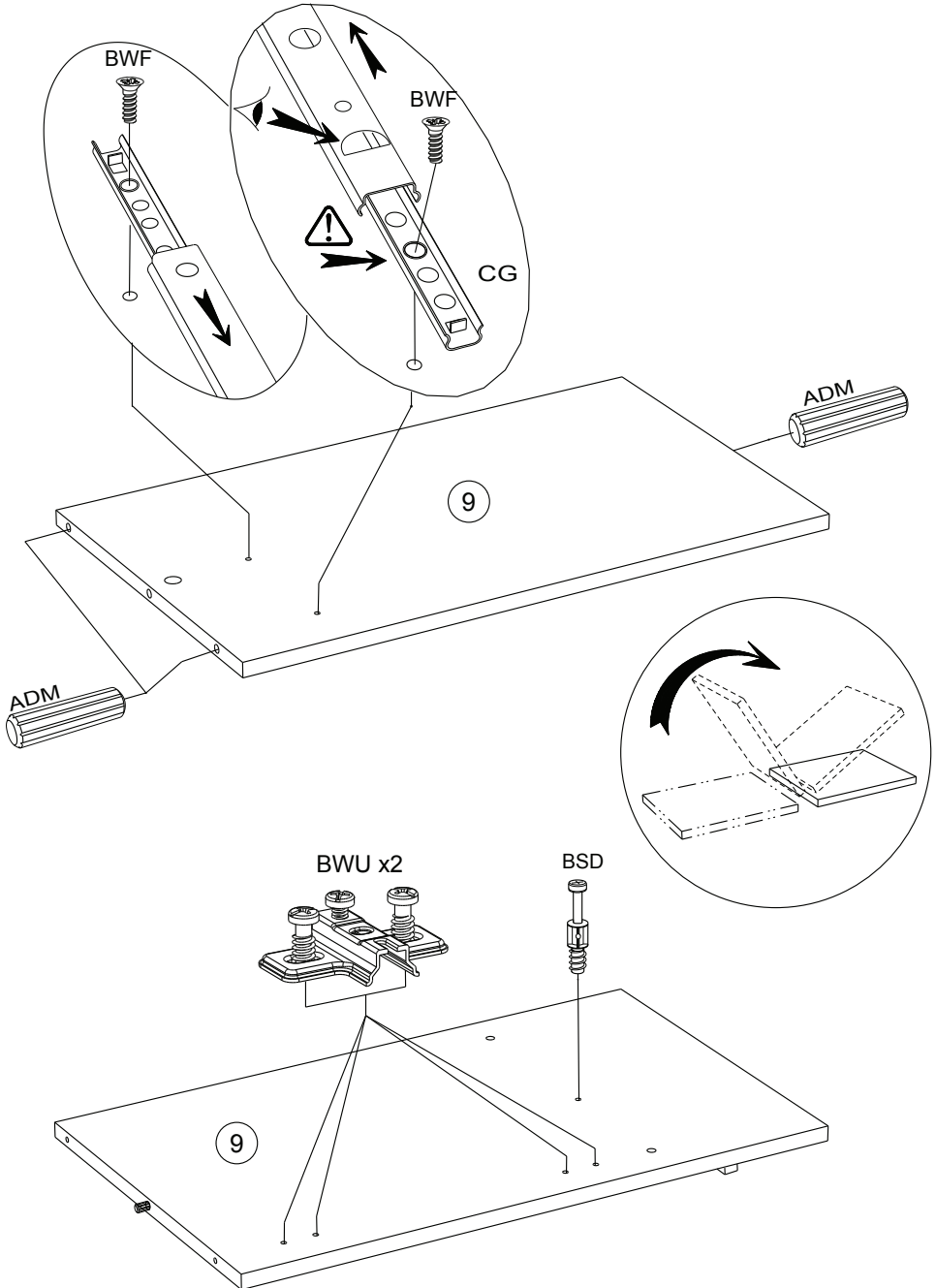



6

ADM x 5

BSD x 1

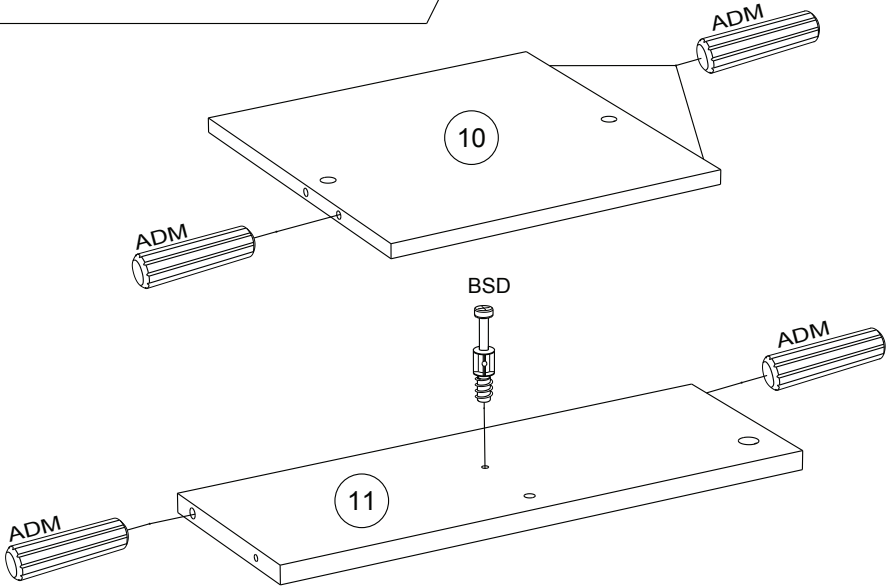

7

ADM x 4

DR x 2

WH x 2

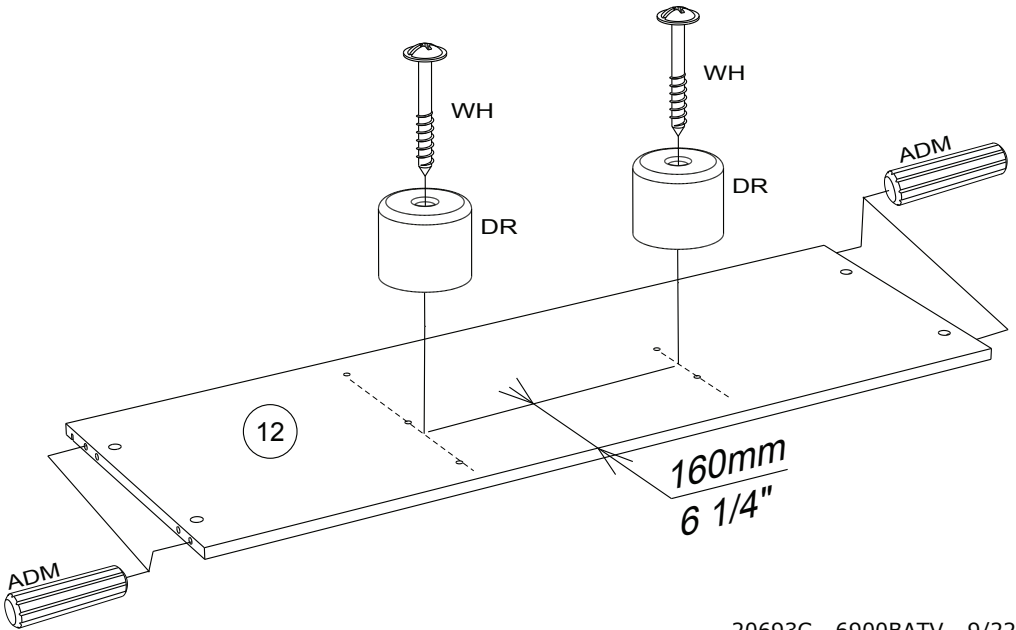

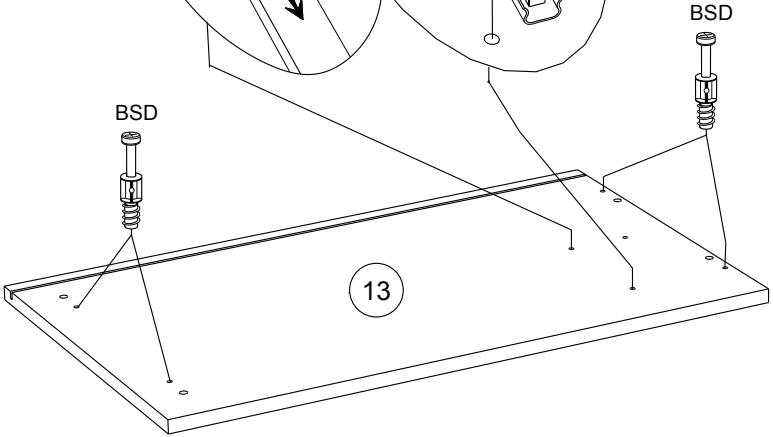
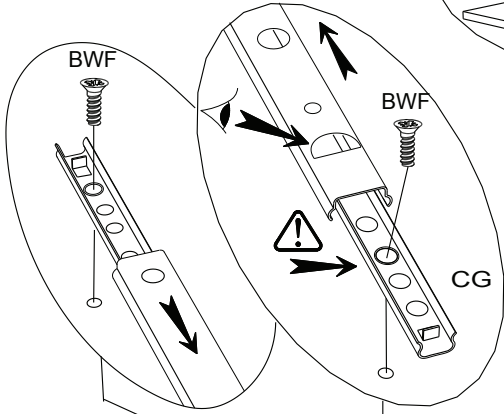
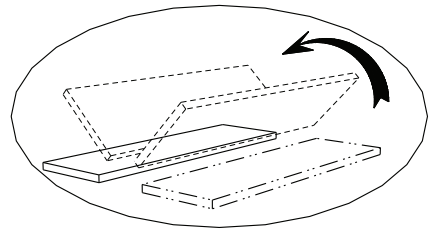
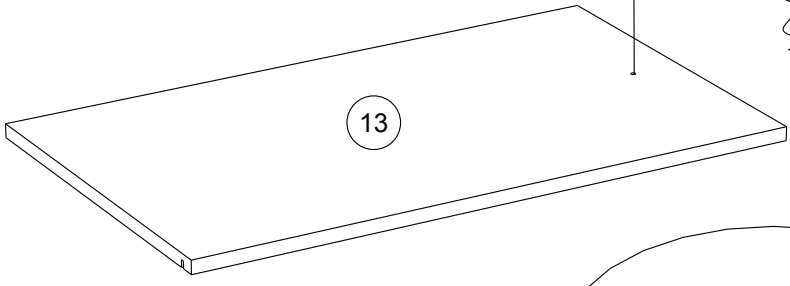
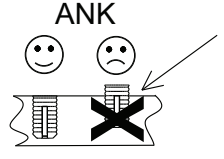
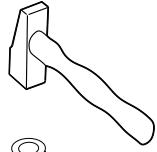
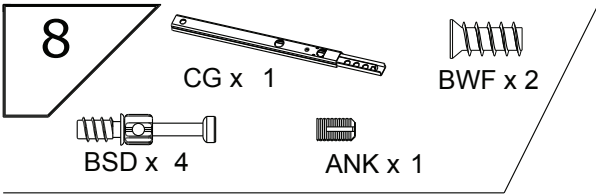

9



Ai x 2

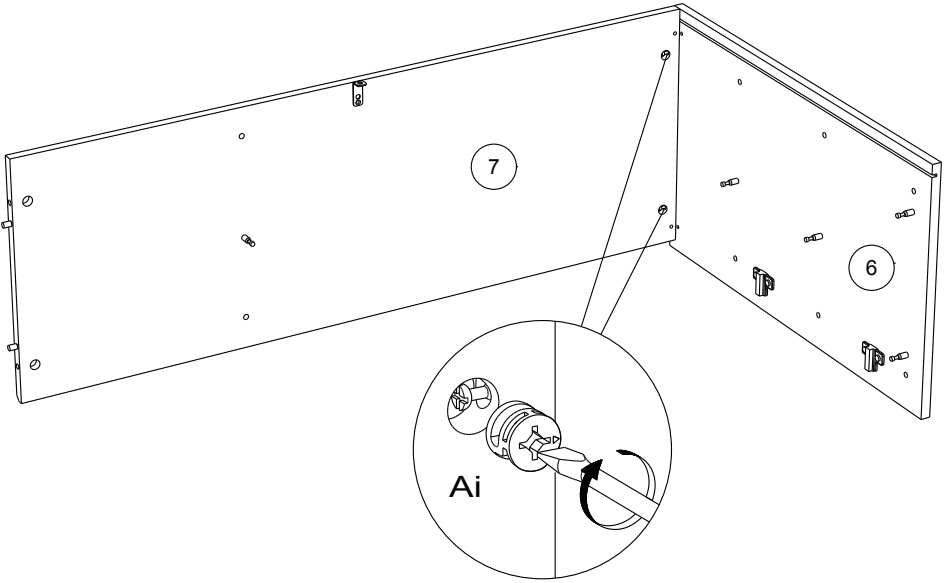

10



BAG x 2



VB x 2

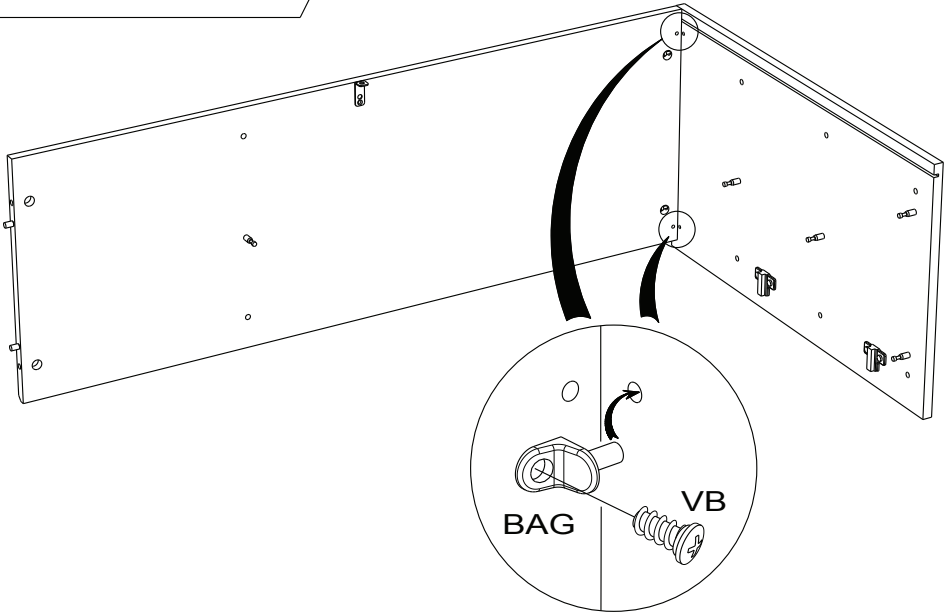

11



Ai x 1

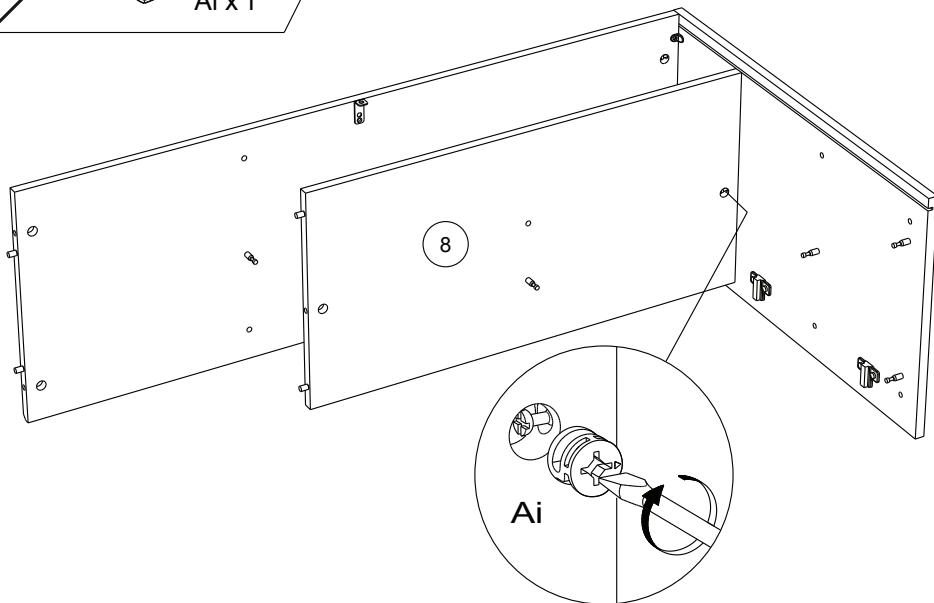

12



Ai x 2

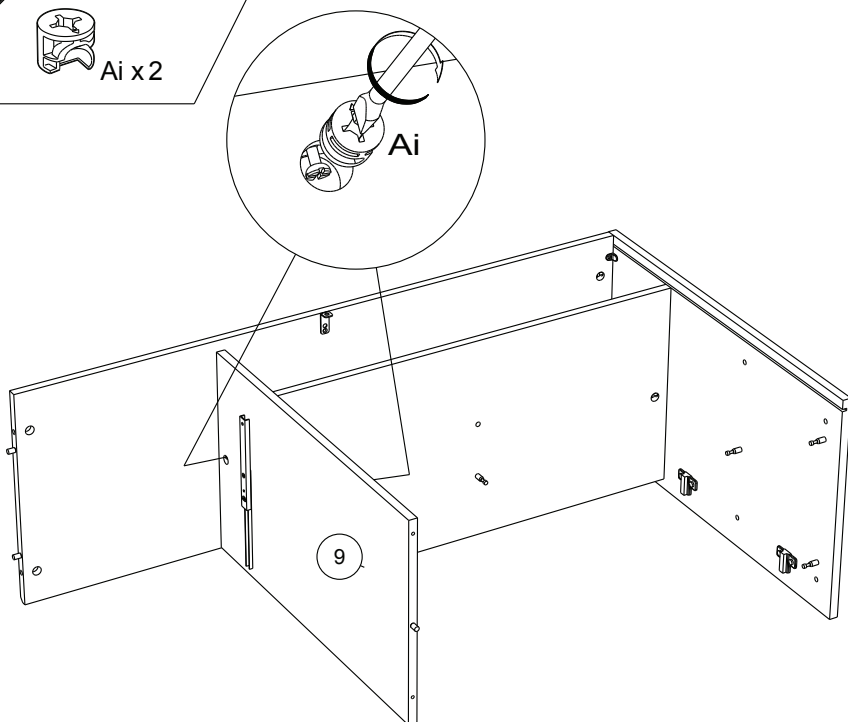

13



Ai x1

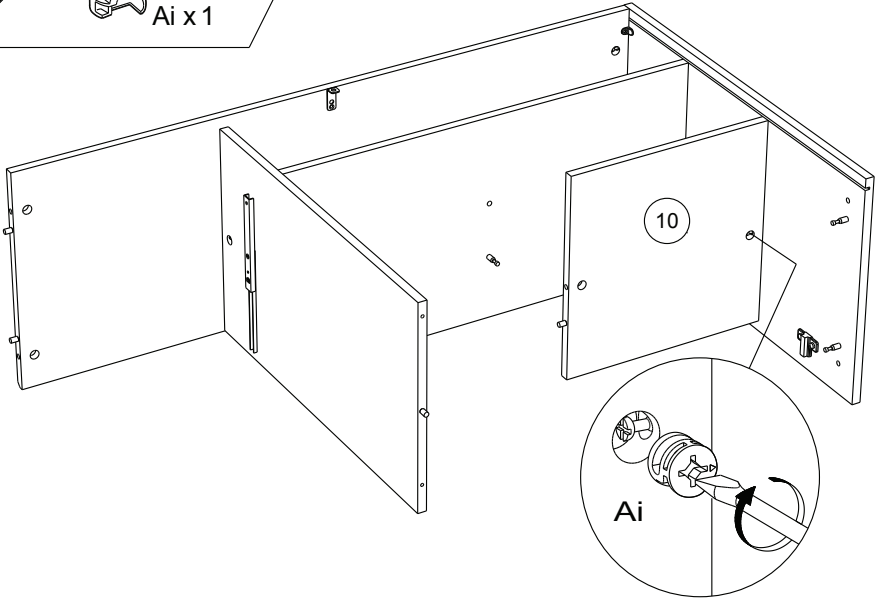

14



Ai x2

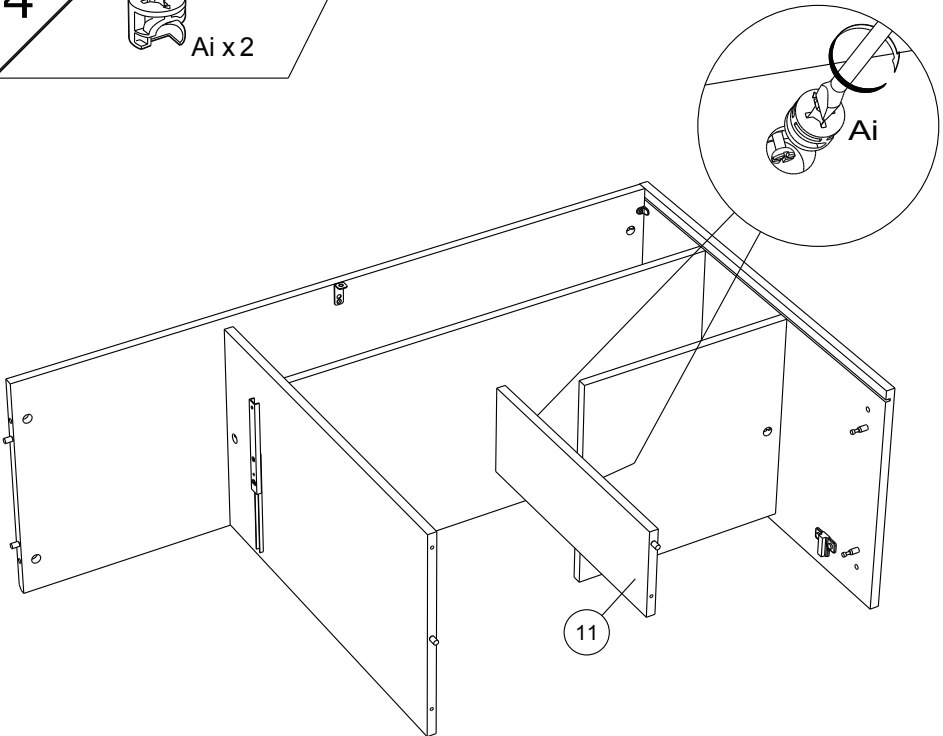

15

HW x 3

Ai x 2

HV x 1

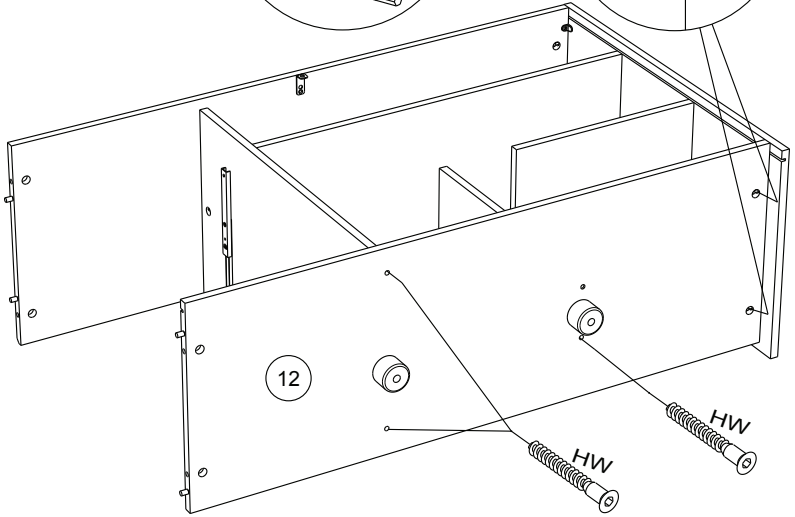
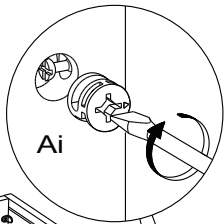
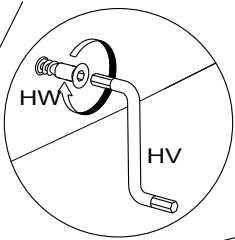

16

Ai x 4

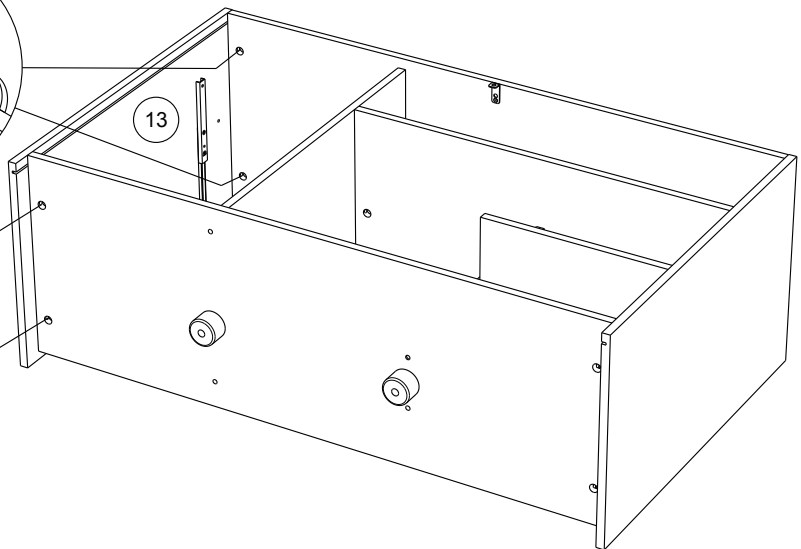
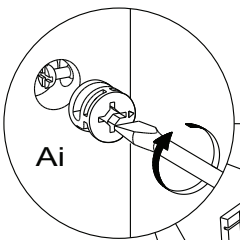

17

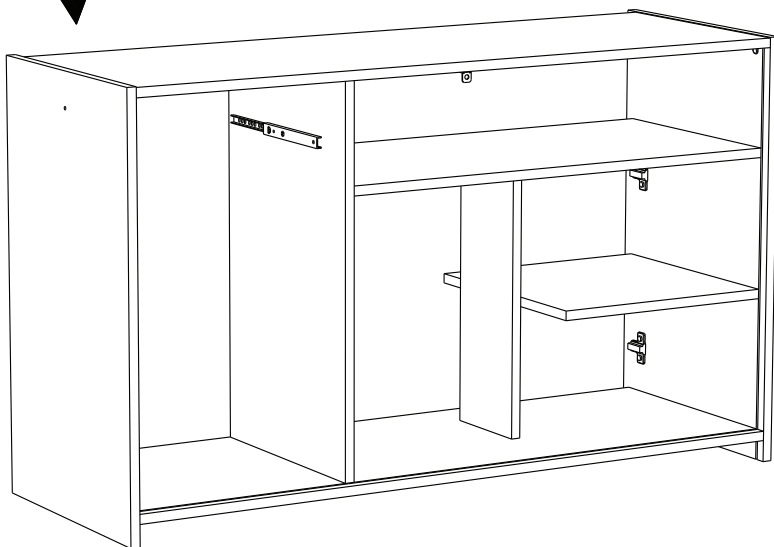
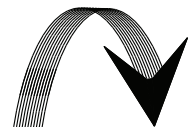
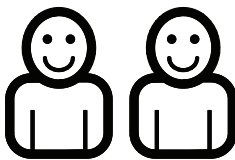

18

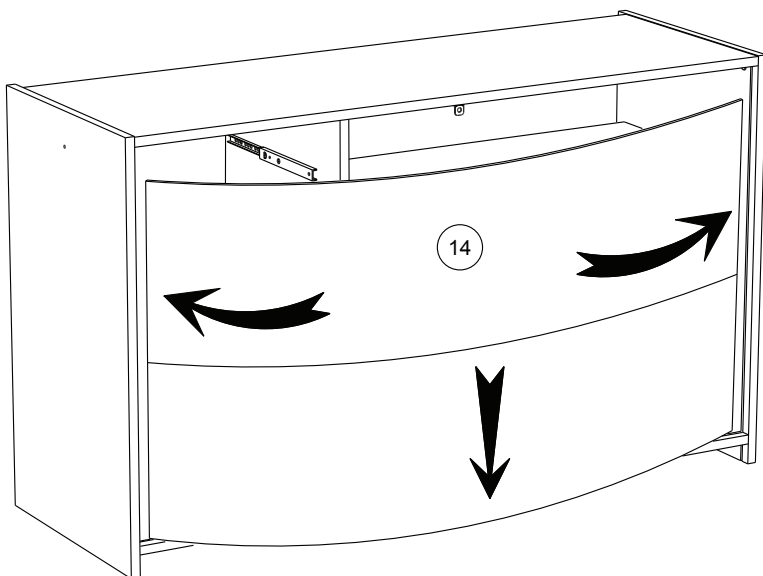

19



EP x4

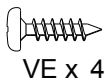

VE x 4

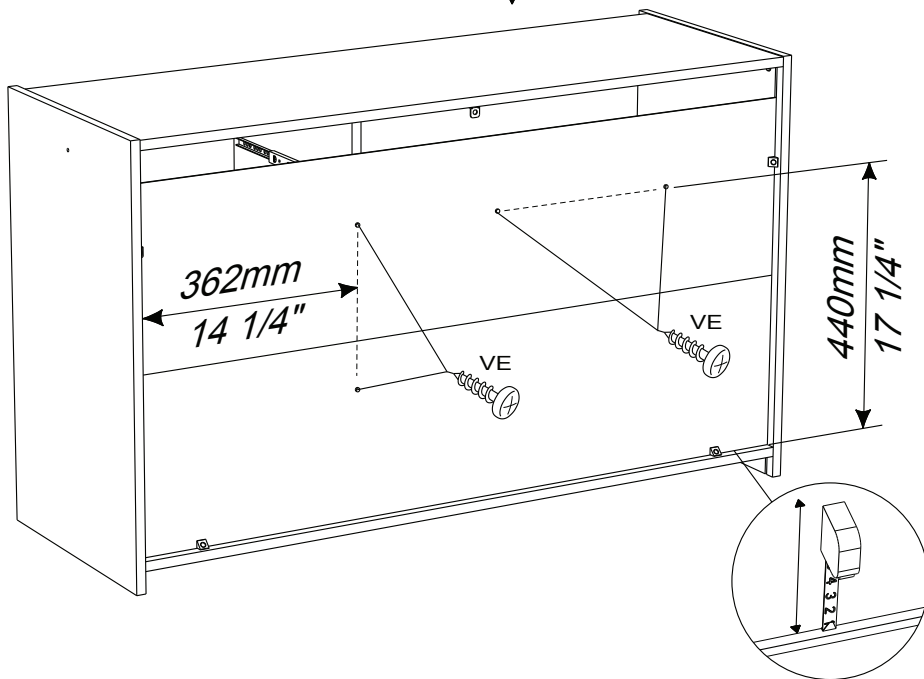
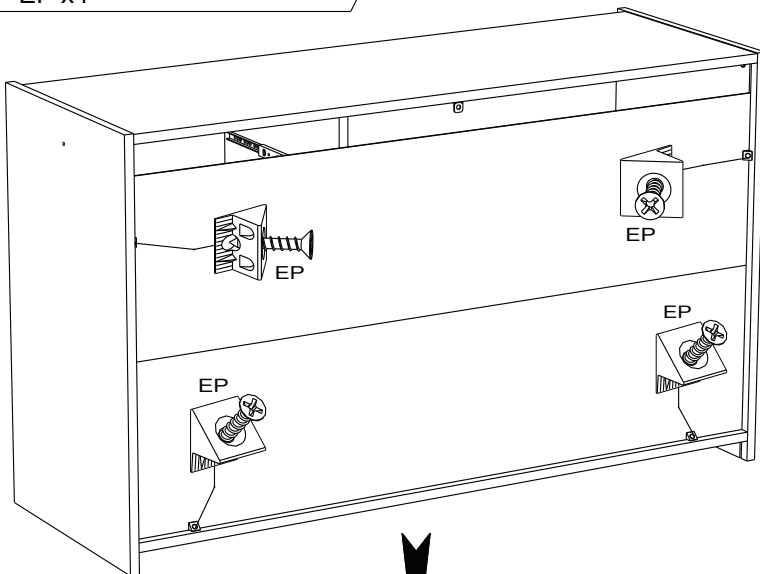



20

BWY x2

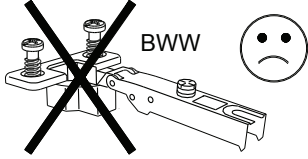
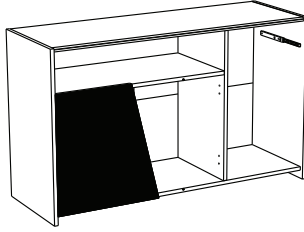
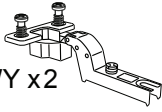

BWW

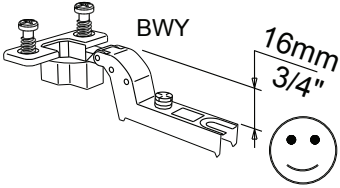

BWY

16mm  
3/4"

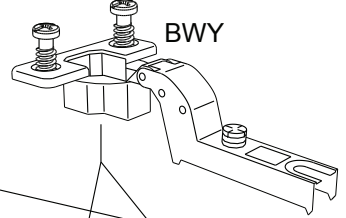

BWY

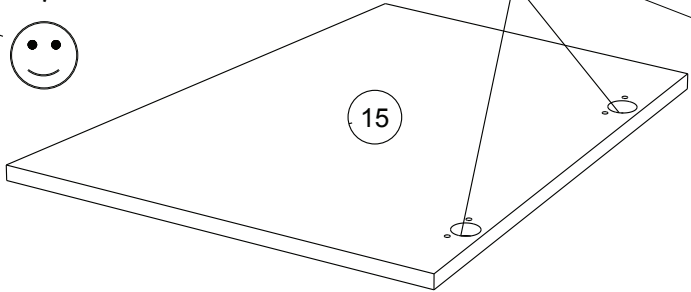

21

BWW x2

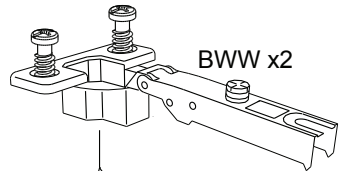
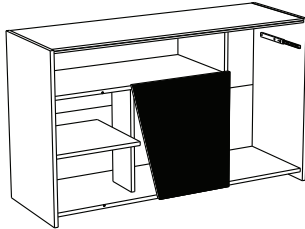
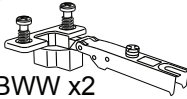

BWW x2

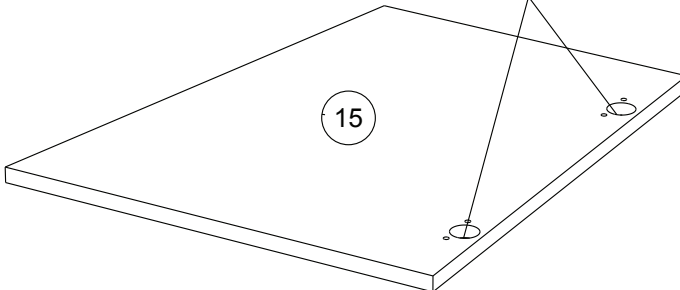

22

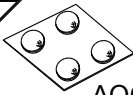

AQO x 1

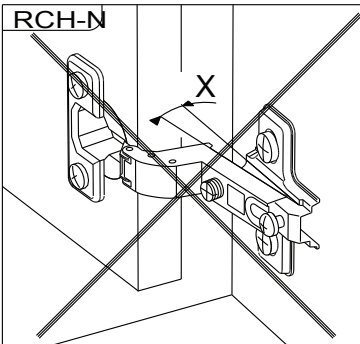
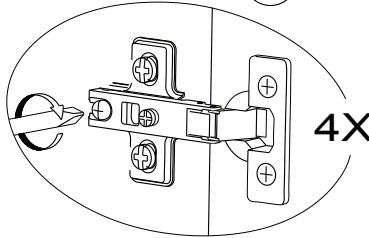
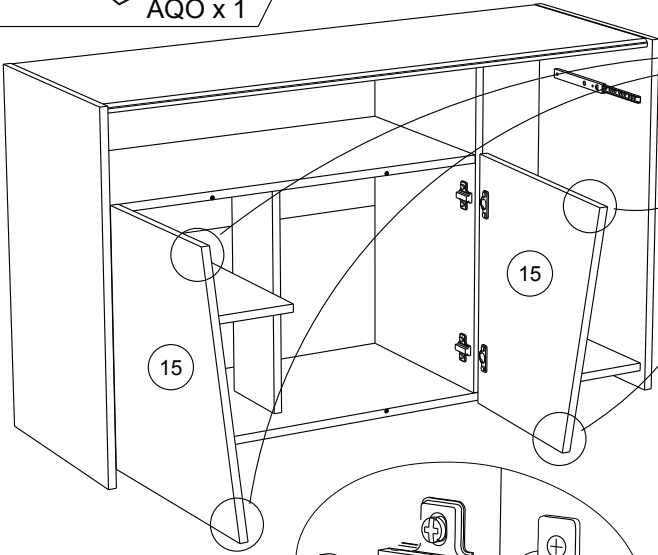

**MONTAGE**

- Ⓒ GB LEAFLET
- Ⓓ D AUFBAUANLEITUNG
- Ⓔ E MONTAJE
- Ⓟ P MONTAGEM
- Ⓜ I MONTAGGIO
- Ⓝ NL MONTAGE

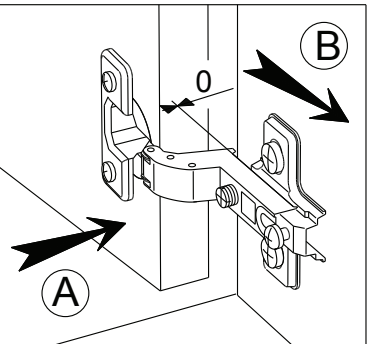

REGLAGE Ⓒ GB ADJUSTING Ⓔ E AJUSTER Ⓜ I AGGIUSTAMENTO  
 Ⓓ D ANPASSUNG Ⓟ P REGULACAO Ⓝ NL AFSTELLING

**A**

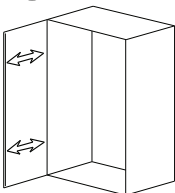

**B**

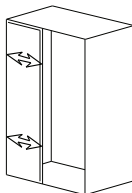

**C**

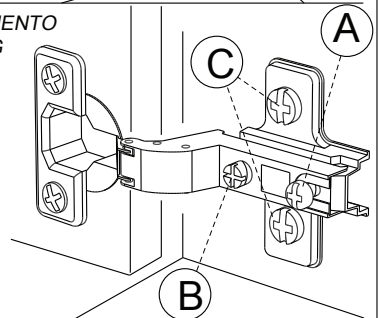
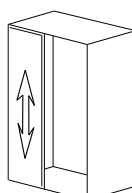

23



CSM x 1



WJ x 2

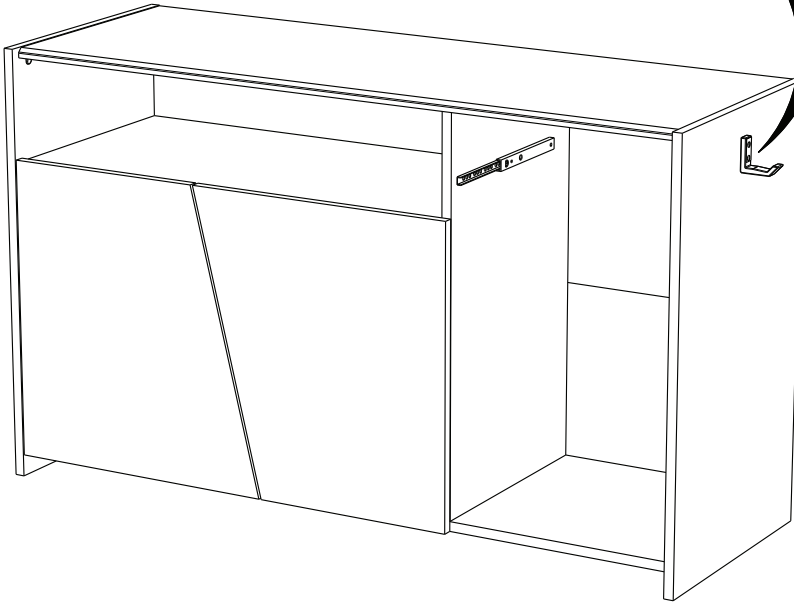
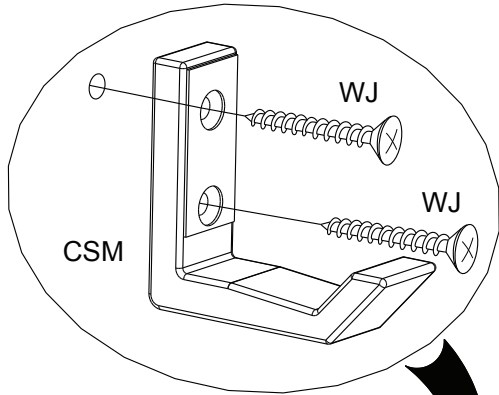

24

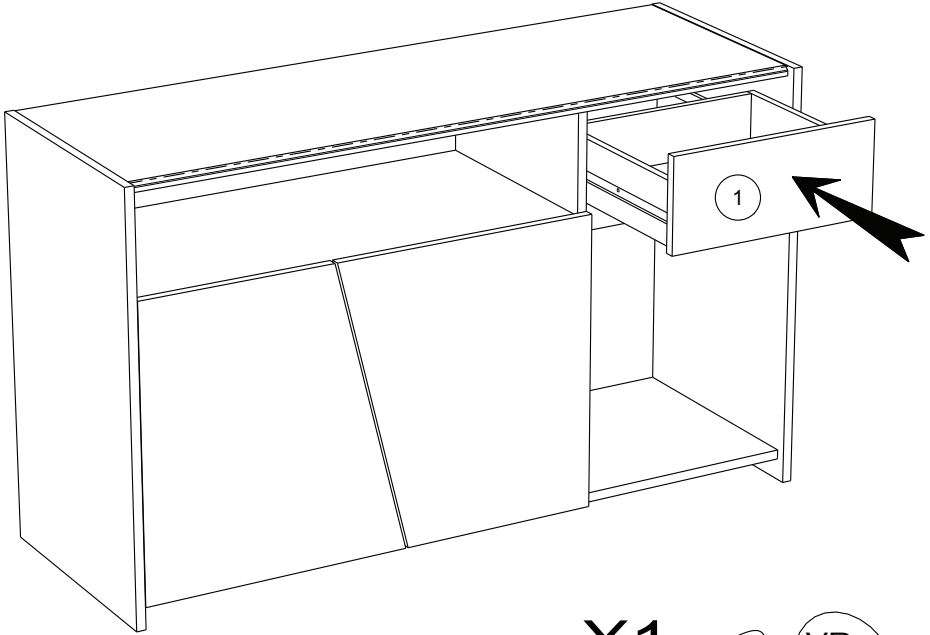
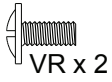

X1

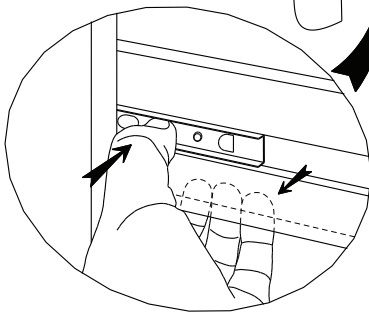
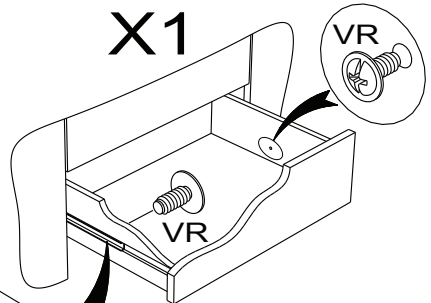

- FR OBLIGATOIRE:** Pour votre sécurité, fixation du meuble au mur.  
Attention, la fixation doit être réalisée par une personne compétente car cela nécessite des chevilles et des vis adaptées à la nature de votre mur. (non fournies)
- EN OBLIGATORY:** For your safety, due to risk of overturning, this product must be used with the wall attachment device provided, this should be carried out by a competent person.
- DE OBLIGATORISCH:** Zu Ihrer Sicherheit, befestigen Sie das Möbel an der Wand.  
Achtung: Diese Befestigung ist durch eine fachlich kompetente Person vorzunehmen.  
Hierfür sind für die Bauweise Ihrer Wand geeignete Dübel einzusetzen.
- ES OBLIGATORIO:** Por su seguridad, fijar el mueble a la pared.  
Advertencia: la fijación la ha de llevar a cabo por personal adecuado, ya que requiere el uso de tacos que se adapten al tipo de pared.
- PT OBRIGATORIO:** Para sua segurança, fixação do móvel ao muro.  
Atenção: a fixação deverá ser efetuada por pessoa habilitada, visto que são necessárias cavilhas adaptadas ao tipo de parede.
- IT OBBLIGATORIO:** Avvertenza di sicurezza, il fissaggio del mobile a parete deve essere realizzato da una persona competente, in quanto l'operazione richiede l'impiego di tasselli adatti alla natura del muro.
- NL VERPLICHT:** Voor uw veiligheid, bevestiging van het meubel aan de muur.  
Opgelet de bevestiging moet worden uitgevoerd door een bekwaam persoon daar dit voor uw type muur geschikte pluggen vereist.
- CZ POVINNÝ:** Z bezpečnostních důvodů, upevněte nábytek do zdi.  
Pozor, upevnění je třeba svěřit kompetentní osobě, neboť vyžaduje hmoždinky vhodné pro vaši zed'.
- HU KÖTELEZŐ:** Az Ön biztonsága érdekében, a bútor falra rögzítése.  
Figyelmeztetés : a rögzítés csak megfelelő szakképesítéssel rendelkező személy által végezhető el, mert a rögzítéshez a falnak megfelelő csavarokra van szükség.
- PL OBOWIĄZKOWY:** Dla bezpieczeństwa, mocowanie mebla do ściany.  
Uwaga, mocowanie musi zostać wykonane przez osobę kompetentną, ponieważ wymaga to zastosowania kołków dostosowanych do rodzaju ściany.
- SK POVINNÉ:** Z bezpečnostných dôvodov, nábytok upevnite k stene.  
Dbajte na to, aby upevnenie vykonala kompetentná osoba, pretože pri upevňovaní sa vyžadujú kolíky vhodné do materiálu, z ktorého je stena vyrobená.
- EL ΥΠΟΧΡΕΩΤΙΚΟΣ :** Για την ασφάλειά σας στερέωση των επίπλων στον τοίχο.  
Προσοχή, η στερέωση πρέπει να γίνεται από ικανό άτομο, καθώς απαιτούνται σφήνες προσαρμοσμένες στη φύση του τοίχου σας.

**AR** واجب : لسلامتک الشخصية، تثبيت قطعة الأثاث على الحائط  
تحذير، يجب أن يقوم شخص متخصص بعملية التثبيت على الحائط إذ أنها تتطلب اسفينا معينا يتوافق مع طبيعة الحائط نفسه.

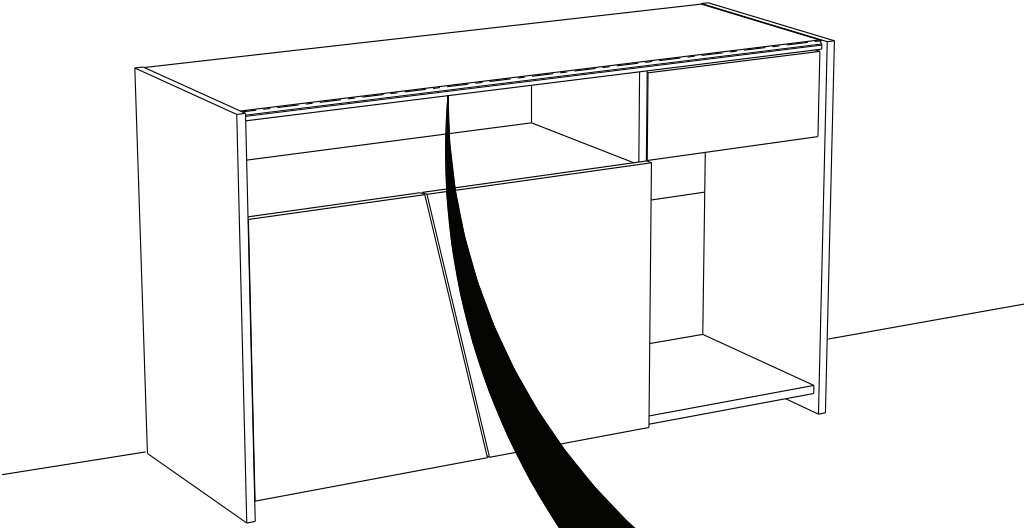

NON INCLUE.  
NO INCLUIDO.  
NOT INCLUDED.  
WERDEN NICHT.  
MITGELIEFERT.  
NIET INBEGREPEN.  
DAHIL DEGIL.

